

# Spectrothermodynamic Relationship of Cationic vs Anionic Species Derived from Protonation vs Deprotonation of Pyrrolo-aza-Aromatic Bases in Homologous Series

J. Catalán

Contribution from the Departamento de Química Física Aplicada, Universidad Autónoma de Madrid, Cantoblanco, E-28049 Madrid, Spain

Received November 6, 2000

**Abstract:** Theoretical research on the spectroscopy and protonation energies of ionic species related to the neutral pyrrolo-aza-aromatic bases has been carried out, using Density Functional Theory (DFT) and its time dependent form (TDDFT). In the ionic species the skeleton localized (+) and (−) charge in the protonated and deprotonated species is shown to have a strong perturbation of the  $\pi$ -electronic states. The lowest electronic  $S_0 \rightarrow S_1$  ( $\pi, \pi^*$ ) transitions are shown to have near-coincidence for each cation and anion for the whole homologous series, in agreement with the Valle–Kasha–Catalán rule previously stated. It is further demonstrated that *simultaneous* dramatic changes, upon electronic excitation, in acidity and basicity at the pyrrolo- and aza-positions of the molecular skeleton are the driving force for the biprotonic phototransfer processes in these bases. This constitutes confirmation of the proton-transfer rather than H-atom transfer as the reaction mechanism.

## Introduction

Azaheterocyclic compounds<sup>1,2</sup> are highly important because they are involved in a biochemical process of special relevance. Thus, some are constituents of DNA (the purine bases), others are the prototypes of photoprotectors (e.g. Tinuvin P), and still others are parts of the active sites of all heme proteins involved in the biological functions of oxygen transport (hemoglobin), electron transport (e.g. cytochrome in respiration), and biocatalysis (e.g. enzymes such as catalases and peroxidases, and Cytochrome P450). Physicochemically, pyrrolo-aza-aromatic (PAA) compounds are highly flexible as their structure includes an acid function (the pyrrole nucleus) and a basic one (e.g. pyridine nucleus) that exhibit a strong mutual interaction.<sup>3</sup> This enables the very easy modeling of a variety of biological functions ranging from UV light-induced mutation (e.g. that observed in 7-azaindole dimer) to complex enzymatic processes on the basis of these PAA structures. Also, the simultaneous basicity and acidity due to the pyrrole and pyridine nuclei in azole compounds have proved to be so strongly correlated that they result in a linear relationship between the corresponding constants, viz.  $pK_a$ (acid, NH) and  $pK_a$ (basic, N):<sup>3</sup> This type of compound has also enabled the development of the Taft scheme for electrostatic proximity effects.<sup>4,5</sup>

The 7-azaindole (7AI) and 1-H-pyrrolo[3,2-*h*]quinoline (1HPQ) molecules have been found to exhibit photoinduced biprotonic transfer, the molecule 7AI serving to first demonstrate the

phenomenon of dual proton transfer in the H-bonded dimer and in an H-bonded cyclic solvate.<sup>6</sup> Decades of research on 7AI have followed this initial research,<sup>7</sup> because of its implied relation to DNA base-pair mutations. The 1HPQ molecule was examined, for the first time, as an example of excited-state biprotonic transfer dependently catalyzed by H-bonded solvates.<sup>8</sup>

Recently, the proven identity of the fluorescence spectra for the cationic and anionic forms produced by a proton transfer from the neutral form of the diazaheterocycles 7AI and 1HPQ led del Valle, Kasha, and Catalán<sup>9</sup> to generalize this behavior in a rule that should be applicable to diazaheterocycles. This generalization was discredited by Douhal et al.<sup>10</sup> on the grounds that the evidence provided by Kasha et al. was fortuitous and that reported fluorescence spectra for the cationic and anionic forms of hydroxyquinolines are not identical.<sup>11</sup> It will be shown here that this example is inapplicable to the basic concept implied in this rule.

This paper reports data obtained for a body of 10 pyrrolo-aza-aromatic compounds (Chart 1) including an electron-releasing function such as the pyrrole nucleus and an electron-withdrawing function such as the pyridine nucleus as in 7AI and 1HPQ. Data were obtained at the highest computational level available to the author (viz. DFT(B3LYP-6-31G\*\*) for the ground electronic state and TDDFT//B3LYP-6-31G\*\* for the  $\pi$ -electron singlet excited states). This study includes the neutral, cationic, and anionic forms of the six possible conformations

(1) Schfield., K. S.; Grimmett, M. R.; Keene, B. R. T. *The Azoles*; Cambridge University Press: Cambridge, UK, 1976.

(2) Katrizky, A. R.; Rees, C. W., Eds. *Comprehensive Heterocyclic Chemistry*; Pergamon: Oxford, UK, 1984.

(3) Catalán, J.; Abboud, J. L. M.; Elguero, J. *Adv. Heterocycl. Chem.* **1987**, *41*, 187.

(4) Taft, R. W.; Anvia, F.; Taagepera, M.; Catalán, J.; Elguero, J. *J. Am. Chem. Soc.* **1986**, *108*, 3237.

(5) Catalán, J.; Palomar, J.; de Paz, J. L. G. *Int. J. Mass. Spectrom Ion Processes* **1998**, *175*, 51.

(6) Taylor, C. A.; El-Bayoumi, A.; Kasha, M. *Proc. Natl. Acad. Sci. U.S.A.* **1969**, *63*, 253.

(7) Catalán, J.; Kasha, M. *J. Phys. Chem. A* **2000**, *104*, 10812 and references therein.

(8) Del Valle, J. C.; Dominguez, E.; Kasha, M. *J. Phys. Chem.* **1999**, *103*, 2467.

(9) Del Valle, J. C.; Kasha, M.; Catalán, J. *Int. J. Quantum Chem.* **2000**, *77*, 118.

(10) Douhal, A.; Moreno, M.; Lluch, J. M. *Chem. Phys. Lett.* **2000**, *324*, 81.

(11) Mason, S. F.; Philp, J.; Smith, B. E. *J. Chem. Soc. A* **1968**, 3051.

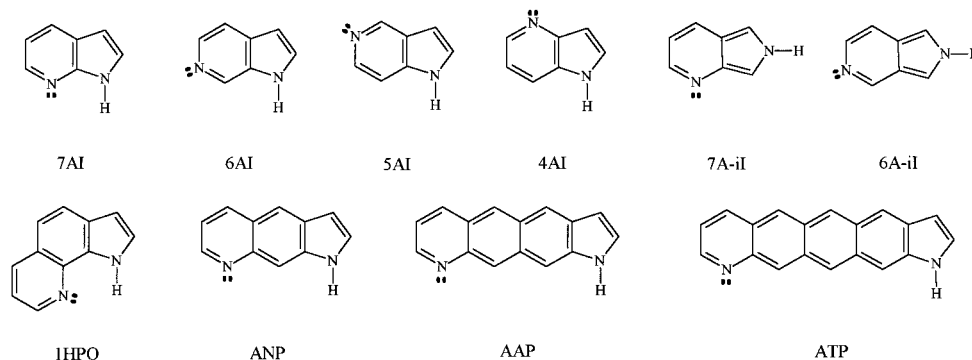
**Chart 1.** Homologous Series of Pyrrolo-aza-Aromatic Bases

on each nucleus in a bicyclic system, viz. the four resonant structures (7AI, 6AI, 5AI, and 4AI) and the two *cis*-dienoid structures (7A-iI and 6A-iI) (see Chart 1). The effect of including additional benzene rings between the two nuclei (structures 1HPQ, ANP, AAP, and ATP in Chart 1) was also examined.

This paper provides answers to such relevant questions on the photophysics of pyrrolo-aza-aromatic compounds such as the following:

(a) In which way does the first electronic transition ( $S_0 \rightarrow S_1$  ( $\pi, \pi^*$ )) in the cationic and anionic forms of diazaheterocyclic compounds deviate from that in their neutral forms?

(b) As a test of the Valle–Kasha–Catalán rule, do the  $S_0 \rightarrow S_1$  ( $\pi, \pi^*$ ) transitions for the cationic and anionic forms of these compounds correspond?

(c) What consequences of the electronic transition correspondence may one expect from the acidity and basicity changes resulting from electronic excitation in this type of compound?

(d) What implications would such changes have on the proton phototransfer in these compounds? In other words, is phototransfer in these compounds controlled by the acidity and basicity changes (i.e. proton transfer) or is it not (i.e. hydrogen atom transfer)?

## Theoretical Background

All computations were done within the framework of the Density Functional Theory (DFT), using the Gaussian 98 software package.<sup>12</sup> Full geometry optimizations for the electronic ground state were carried out by using the hybrid functional B3LYP<sup>13,14</sup> with the 6-31G\*\* basis set. The optimized geometries for the ground state were used to compute the Franck–Condon (FC) excitation energies for the singlet excited states ( $S_1$  ( $\pi, \pi^*$ )) in light of the recently developed Time-Dependent Density Functional Theory (TDDFT), which has yielded excellent results so far.<sup>15,16</sup>

(12) Frisch, M. J.; Trucks, G. W.; Schlegel, H. B.; Scuseria, G. E.; Robb, M. A.; Cheeseman, J. R.; Zakrzewski, V. G.; Montgomery, J. A.; Stratmann, R. E.; Burant, J. C.; Dapprich, S.; Millan, J. M.; Daniels, A. D.; Kudin, K. N.; Strain, M. C.; Farkas, O.; Tomasi, J.; Barone, V.; Cossi, M.; Cammi, R.; Mennucci, B.; Pomelli, C.; Adamo, C.; Clifford, S.; Ochterski, J.; Petersson, G. A.; Ayala, P. Y.; Cui, Q.; Morokuma, K.; Malick, D. K.; Rabuck, A. D.; Raghavachari, K.; Foresman, J. B.; Cioslowski, J.; Ortiz, J. V.; Stefanov, B. B.; Liu, G.; Liashenko, A.; Piskorz, P.; Komaromi, I.; Gompers, R.; Martin, R. L.; Fox, D. J.; Keith, T.; Ai-Laham, M. A.; Peng, C. Y.; Nanayakkara, A.; Gonzalez, C.; Challacombe, M.; Gill, P. M. W.; Johnson, B. G.; Chen, W.; Wong, M. W.; Andrés, J. L.; Head-Gordon, M.; Replogle, E. S.; Pople, J. A. *Gaussian 98*; Gaussian Inc.; Pittsburgh, PA, 1998.

(13) Becke, A. D. *J. Chem. Phys.* **1993**, *98*, 5642.

(14) Lee, C.; Yang, W.; Parr, R. G. *Phys. Rev. B* **1988**, *3*, 785.

(15) Wiberg, K. G.; Stratmann, R. E.; Frisch, M. J. *J. Chem. Phys. Lett.* **1998**, *297*, 60.

(16) Hirata, S.; Lee, T. J.; Head-Gordon, M. *J. Chem. Phys.* **1999**, *111*, 8904.

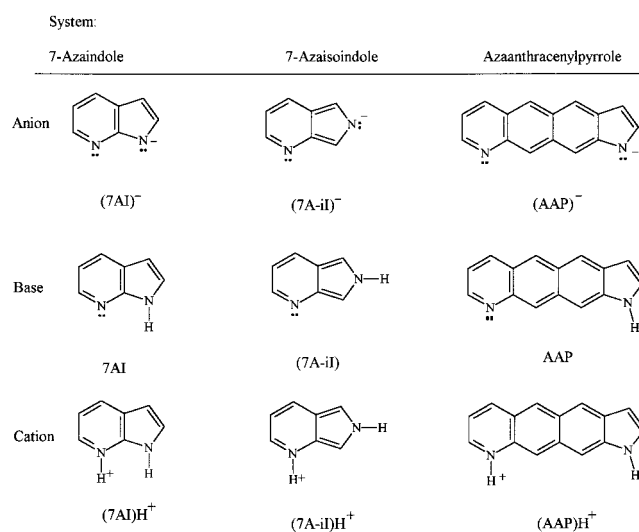
**Chart 2.** Anion–Cation Pairs from Pyrrolo-aza-Aromatic Bases

Protonation (eq 1) and deprotonation energies (eq 2) were both positive as they were expressed as the acidity of the protonated and neutral form, respectively. These values were computed as the differences between the total energy for the neutral and ionic forms directly involved in the equilibria in both the ground electronic state ( $\Delta E_{\text{prot}}$  and  $\Delta E_{\text{deprot}}$ ) and the first  $\pi, \pi^*$  singlet excited state [ $S_1$  ( $\pi, \pi^*$ )] ( $\Delta E_{\text{prot}}^*$  and  $\Delta E_{\text{deprot}}^*$ ):



## Results and Discussion

Because all PAA compounds studied were at least bicyclic (see Chart 1), their first electronic transition should be of the  $\pi \rightarrow \pi^*$  type. Also, because the neutral, cationic, and anionic forms of these compounds (Chart 2) preserved their  $\pi$ -electron skeleton, the transition might be expected to take place at the same energy for the three corresponding species. However, this is not the case, because the charged forms result from the neutral form gaining or losing a proton in the  $\sigma$ -skeleton of the molecule, in other words, an electrostatic perturbation arises from the localization of a negative or positive charge on the  $\sigma$ -framework. These compounds are thus suitable models for determining how a localized charge in the  $\sigma$ -skeleton perturbs the  $\pi \rightarrow \pi^*$  electronic transitions of the molecule.

Table 1 shows the wavelengths calculated for the first  $S_0 \rightarrow S_1$  ( $\pi, \pi^*$ ) electronic transitions in the neutral, anionic, and cationic forms of the 10 PAA compounds studied. Such a  $\pi \rightarrow$

**Table 1.** Wavelength for the First  $\pi \rightarrow \pi^*$  Transition in the PAA Compounds Studied, Energy Difference between the Transition in the Cationic (PAA)H<sup>+</sup> and Anionic (PAA)<sup>-</sup> Forms and that of the Neutral Form of the Compound ( $\Delta E_1$ ), and Energy Difference between the First  $\pi \rightarrow \pi^*$  Transition in the Cation and That in the Anion ( $\Delta E_2$ )

compd	$\lambda$ (in nm)	$\Delta E_1$ (kcal/mol)	$\Delta E_2$ (kcal/mol)
7AI	263.7	0	
(7AI)H <sup>+</sup>	317.7	-18.4	1.6
(7AI) <sup>-</sup>	324.3	-20.3	0
6AI	258.0	0	
(6AI)H <sup>+</sup>	303.5	-16.6	-0.5
(6AI) <sup>-</sup>	301.8	-16.1	0
5AI	252.1*	0	
(5AI)H <sup>+</sup>	300.9	-16.4	1.0
(5AI) <sup>-</sup>	303.8	-17.4	0
4AI	262.0*	0	
(4AI)H <sup>+</sup>	312.3	-16.8	3.5
(4AI) <sup>-</sup>	324.9	-20.3	0
7A-iI	324.6	0	
(7A-iI)H <sup>+</sup>	407.4	-17.9	-0.7
(7A-iI) <sup>-</sup>	403.1	-17.2	0
6A-iI	308.9	0	
(6A-iI)H <sup>+</sup>	378.4	-17.0	-3.0
(6A-iI) <sup>-</sup>	363.8	-14.0	0
1HPQ	314.7	0	
(1HPQ)H <sup>+</sup>	391.6	-17.9	-1.1
(1HPQ) <sup>-</sup>	386.0	-16.8	0
ANP	351.0	0	
(ANP)H <sup>+</sup>	487.7	-22.8	1.4
(ANP) <sup>-</sup>	499.4	-24.2	0
AAP	463.4	0	
(AAP)H <sup>+</sup>	775.0	-24.8	0.2
(AAP) <sup>-</sup>	778.9	-25.0	0
ATP	597.2	0	
(ATP)H <sup>+</sup>	1258.7	-25.2	0.3
(ATP) <sup>-</sup>	1278.0	-25.5	0
7HQ	302.9	0	
(7HQ)H <sup>+</sup>	355.3	-13.9	13.8
(7HQ) <sup>-</sup>	428.8	-27.7	0

\* The first excited singlet for these compounds is of the  $n \rightarrow \pi^*$  type, and is predicted to occur at 256.5 nm in 5AI and 263.8 nm in 4AI.

$\pi^*$  transition has a dominant contribution of the HOMO–LUMO transition. Only the neutral forms of 4AI and 5AI were found to depart from this general behavior: their first singlet excited state was of the  $n, \pi^*$  type, and predicted to occur at 263.8 and 256.5 nm, respectively. The data allow one to draw two interesting conclusions, namely:

(a) The first electronic transition in both the cationic and the anionic forms occurs at substantially lower energies than it does in the neutral form, with  $\Delta E_1 = 14$ – $25$  kcal/mol.

(b) The energies of the transitions in the cationic and anionic forms as calculated at the TDDFT//B3LYP-6-31G\*\* level are virtually identical (see  $\Delta E_2$  values in Table 1 and Figure 1), so these compounds obey the rule of Valle–Kasha–Catalán.<sup>9</sup> Note that the electronic transitions for the ionic forms considered span a very broad wavelength range (from the UV to the IR region).

The fact that both the  $S_0 \rightarrow S_1$  ( $\pi, \pi^*$ ) transition for the protonated form ( $\sigma$ -cation) and that for the deprotonated one ( $\sigma$ -anion) occur at an intrinsically lower energy ( $\Delta E_1 = 14$ – $25$  kcal/mol) than that for the neutral form clearly indicates that the localized charge skeletal perturbation has a stronger stabilizing effect on the excited electronic state than it has on the ground state. Most surprisingly, however, the stabilization effect does not depend on the sign of the charge, which suggests that it exhibits an even-order dependence on  $\Delta E_1$ , like the polarizability.

While the respective positive and negative charges of the protonated and deprotonated forms of PAA are located on their

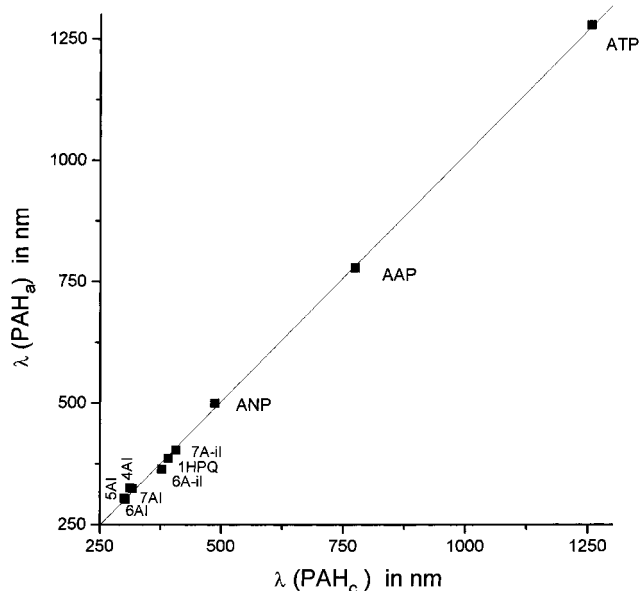

**Figure 1.** Plot of the  $S_0 \rightarrow S_1$  ( $\pi, \pi^*$ ) electronic transition energies calculated for the anion species vs that of the cation species for the 10 pyrrolo-aza-aromatic molecules (PAA) (Table 1).

$\sigma$ -skeleton, with no orbital mixing with the  $\pi$  cloud, this cannot be the case with hydroxyquinolines; in fact, while the protonated form with the proton on the heterocycle of these compounds can be expected to maintain its charge localized on the  $\sigma$  skeleton, the hydroxyl group in the deprotonated form will enable delocalization of the negative charge in the  $\pi$  cloud and result in increased stabilization relative to the cationic form. In support of these assumptions are the TDDFT//B3LYP-6-31G\*\* computations (Table 1). On the whole, the energies for the ionic forms of the bicyclic compounds studied depart by 1.7 kcal/mol in absolute terms, whereas that for 7-hydroxyquinoline differs by 13.8 kcal/mol (see  $\Delta E_2$  in Table 1). This deviation results from over-stabilization of the ionic form (see  $\Delta E_1$  in Table 1), which can delocalize its charge in the  $\pi$  cloud. In conclusion, as expected, hydroxyquinoline does not obey the rule of Valle–Kasha–Catalán.<sup>9</sup>

If, as predicted by the TDDFT//B3LYP-6-31G\*\* calculations, the structures (PAA)H<sup>+</sup> and PAA<sup>-</sup> are assumed to exhibit  $S_0 \leftrightarrow S_1(\pi, \pi^*)$  transitions of roughly identical energy, one can investigate the photophysical implications of the phenomenon. Scheme 1 depicts the corresponding Förster cycle, which comprises both the acidity and the basicity of the PAA compound.

Based on the basicity cycle, the following equality can be formulated:

$$\Delta E_{\text{prot}} + E_{\text{PAA}} = \Delta E_{\text{prot}}^* + E_{(\text{PAA})\text{H}^+} \quad (3)$$

which can be rearranged to

$$E_{\text{PAA}} - E_{(\text{PAA})\text{H}^+} = \Delta E_{\text{prot}}^* - \Delta E_{\text{prot}} = \Delta \Delta E_{\text{prot}} \quad (4)$$

where  $\Delta \Delta E_{\text{prot}}$  is the basicity change in the compound upon electronic excitation.

Similarly, the following equality can be formulated from the acidity cycle:

$$\Delta E_{\text{deprot}} + E_{\text{PAA}^-} = \Delta E_{\text{deprot}}^* + E_{\text{PAA}} \quad (5)$$

which can be rearranged to

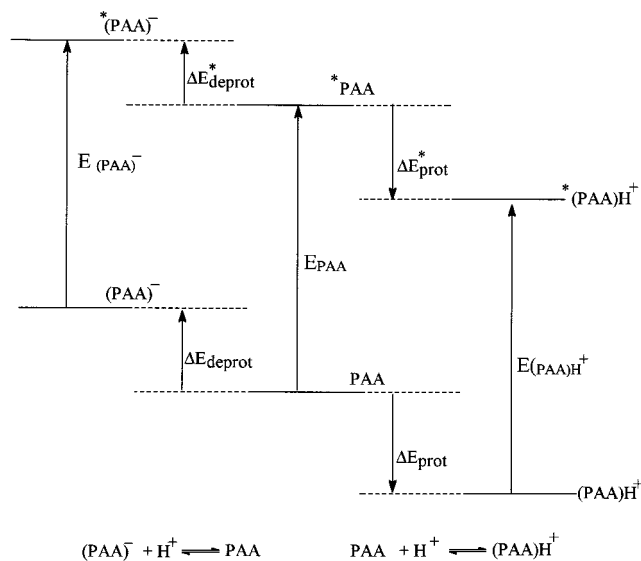
**Scheme 1.** Absorption Spectroscopy and Protonation/Deprotonation Energy Perturbations of Cation/Anion Species vs PAA Bases

$$E_{PAA^-} - E_{PAA} = \Delta E_{deprot}^* - \Delta E_{deprot} = \Delta \Delta E_{deprot} \quad (6)$$

where  $\Delta \Delta E_{deprot}$  denotes the acidity change in the compound upon electronic excitation.

Based on eqs 4 and 6, and on the assumption that the first electronic transition in the cationic and anionic forms of these compounds possess the same energy (i.e.  $E_{PAAH^+}/E_{PAA^-}$ ), one can write

$$\Delta \Delta E_{prot} = -\Delta \Delta E_{deprot} \quad (7)$$

Equation 7 reveals that electronic excitation increases the protonation energy to the same extent as it decreases the deprotonation energy, or in other words, that excitation increases basicity by the same amount as it increases acidity. Table 2 gives the acidity and basicity values for the ground and excited states, as well as the basicity and acidity changes in these compounds upon electronic excitation. The data clearly show that these compounds undergo a *simultaneous*, dramatic change in their intrinsic basicity and acidity with electron excitation, and that the change conforms to eq 7. This reveals that the pyrrole nucleus in these compounds resonates strongly with the pyridine nucleus at all the skeleton positions studied, which induces massive charge transfer between them. In view of this behavior one may wonder whether the acidity and basicity of these compounds hold a mutual relation such as that previously demonstrated by this laboratory in azole compounds.<sup>3</sup> Figure 2 shows that the PAA compounds exhibit a linear relation between their acidity and basicity, and that the relation includes not only the ground state but also the excited electronic state. It should be noted that the relation spans a basicity and acidity range of about 40 kcal/mol.

#### A Note on the Phototautomerization Mechanism of 7-Azaindole Dimer

Let us focus on the implications of these facts on the photophysics of the best-known among these PAA molecules: 7AI. This compound has become popular since Kasha et al.<sup>6</sup> demonstrated that, in hydrocarbon solvents, it forms dimers through a double hydrogen bond and that the dimers phototautomerize as shown in Scheme 2. If the first electronic excitation

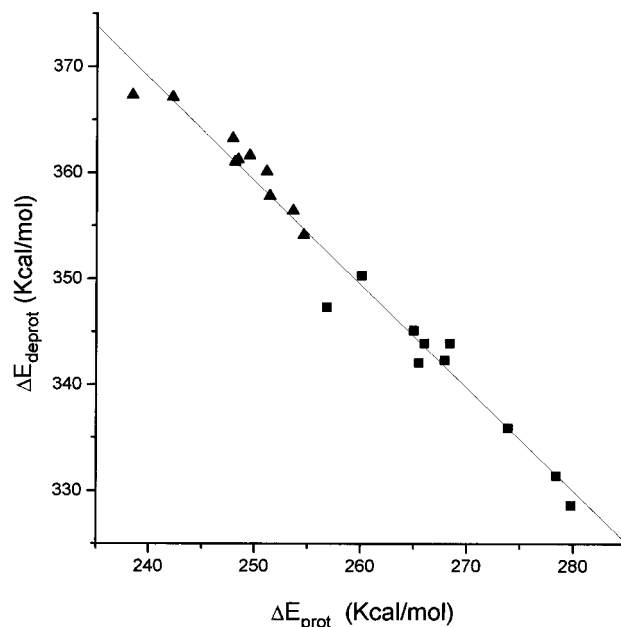
**Figure 2.** Plot of the calculated energies  $\Delta E_{deprot}$  (acidity) vs  $\Delta E_{prot}$  (basicity) for the ground state ( $\blacktriangle$ ) and the energies  $\Delta E_{deprot}^*$  vs  $\Delta E_{prot}^*$  for the first singlet excited state ( $\pi, \pi^*$ ) ( $\blacksquare$ ) for the pyrrolo-aza-aromatic (PAA) molecules (Table 2).**Table 2.** Protonation ( $\Delta E_{prot}$ ) and Deprotonation Energies ( $\Delta E_{deprot}$ ) in the Ground State and the  $1(\pi, \pi^*)^1$  State for the PAA Compounds Studied and Difference from the Values after Electronic Excitation ( $\Delta \Delta E_{prot}$  and  $\Delta \Delta E_{deprot}$ ) (all in kcal/mol)

compd	$\Delta E_{prot}$	$\Delta E_{deprot}$	$\Delta E_{prot}^*$	$\Delta E_{deprot}^*$	$\Delta \Delta E_{prot}$	$\Delta \Delta E_{deprot}$
7AI	238.4	367.3	256.8	347.3	18.4	-20.0
6AI	248.4	361.2	265.0	345.1	16.6	-16.1
5AI	249.5	361.6	267.9	342.3	18.4	-19.3
4AI	247.9	363.2	265.5	342.1	17.6	-21.1
7A-iI	248.1	361.0	266.0	343.9	17.9	-17.1
6A-iI	251.4	357.8	268.4	343.9	17.0	-13.9
1HPQ	242.2	367.1	260.1	350.3	17.9	-16.8
ANP	251.1	360.1	273.9	335.9	22.8	-24.2
AAP	253.6	356.4	278.4	331.4	24.8	-25.0
ATP	254.6	354.1	279.8	328.6	25.2	-25.5

#### Scheme 2. Biprotonic Phototautomerism of 7AI Dimer

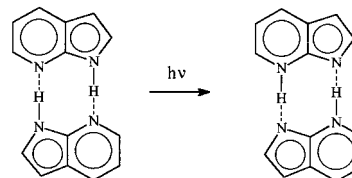

#### Scheme 3. Simultaneous Increase of Acidity and Basicity upon Electronic Excitation

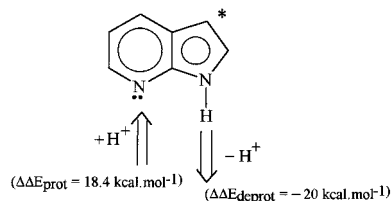

of this compound, of the  $\pi \rightarrow \pi^*$  type, causes an instantaneous increase in the acidity of its N-H pyrrole group, which results in a simultaneous increase in the basicity of the pyridine nucleus (Scheme 3), then both protons in the dimer will be driven *simultaneously* to move to the companion molecule upon

electronic excitation; however, because the dimer delocalizes the excitation over the two moieties,<sup>17,18</sup> the phototransfer must obviously take place in a synchronous (i.e. concerted) manner.

Consequently, the dramatic acidity and basicity changes undergone by these compounds (in the region of 19 kcal/mol) are no doubt the driving forces that lead to their phototautomerization. The magnitude of these changes allows one to conclude that the phototautomerization mechanism for 7AI must involve the transfer of protons rather than that of hydrogen atoms.

## Conclusions

An analysis of the behavior of the first electronic transition ( $S_0 \rightarrow S_1(\pi, \pi^*)$ ) in the protonated and deprotonated forms of PAA has allowed the nature of the interaction, of an electric charge localized on the  $\sigma$ -skeleton, with the transition to be elucidated. The effect is strongly stabilizing and its magnitude is independent of the sign of the charge; also, it results in a virtually identical  $S_0 \rightarrow S_1(\pi, \pi^*)$  transition energy for both charged species, which thus obey the Valle–Kasha–Catalán rule.

Here is presented a refocusing of the Valle–Kasha–Catalán rule, in conformity with the original study, and its present expression:

“In a pyrrolo-aza-aromatic molecule with a *pyrrolo* proton donor site, and an *aza* (*pyridine*) proton acceptor site, a coincidence or near coincidence of the corresponding cation and anion  $S_0 \leftrightarrow S_1(\pi, \pi^*)$  transition bands will be manifested as a

(17) McRae, E. G.; Kasha, M. In *Physical Process in Radiation Biology*; Angenstein, J., Mason, R., Rosenberg, B., Eds.; Academic Press: New York, 1964; p 23.

(18) Kasha, M.; Rawls, H. R.; El-Bayoumi, M. A. *Pure Appl. Chem.* **1965**, *11*, 371.

result of (+) and (–) electrostatic skeletal perturbations on the intact  $\pi$ -electron system.”

The phenomenon described represents a type of intramolecular solvation mostly produced by the polarizability effect. Changing the  $\sigma$  skeleton from neutral to either cationic or anionic species alters the environment within which the  $\pi$ -electron excitation occurs. If the excited states involved in these electronic transitions possessed ionic character, either the cationic or the anionic species would be preferentially stabilized, which is not observed. In contrast, both cationic and anionic species lead to similar stabilization of the excited state. The electronic transition energy shift referred to the neutral species is a measure of the greater polarizability of the excited state relative to the ground state.

As shown in this work, these compounds *simultaneously* undergo dramatic, but identical, changes in acidity and basicity. Because this is the driving force for phototransfer in these compounds, the process must involve protons rather than hydrogen atoms. These results are consistent with a concerted mechanism for the phototautomerization of the 7AI dimer.

**Acknowledgment.** This paper is dedicated to Prof. Michael Kasha on his 80th birthday, in admiration of his great chemical and physical intuition, and his vast and solid scientific foundations. We are greatly indebted to DGICYT of Spain (Project PB98-0063).

**Supporting Information Available:** Tables of theoretical data (PDF). This material is available free of charge via the Internet at <http://pubs.acs.org>.

JA003886F